

# *Mondel Braketronic* Systems

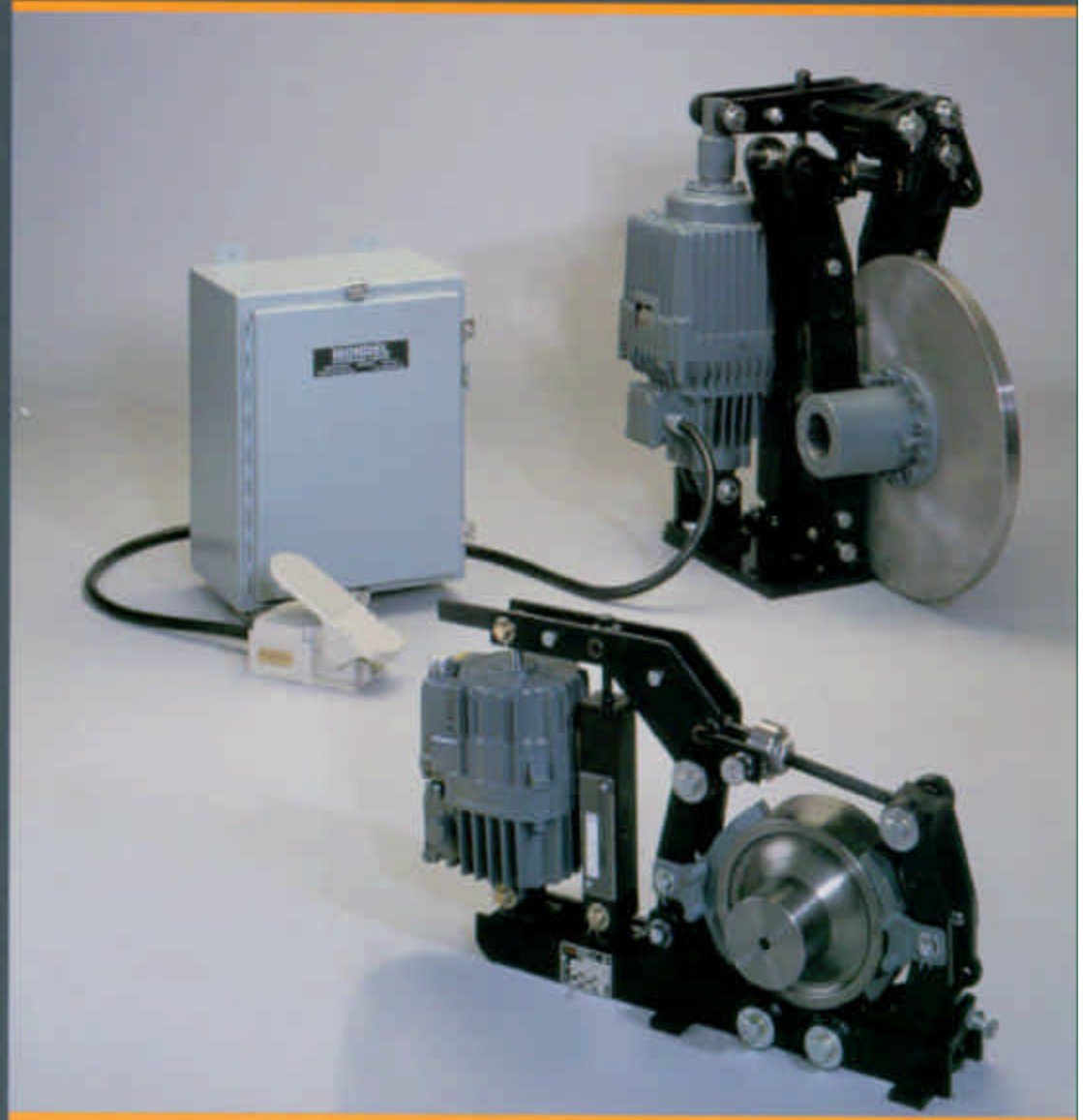

**MONDEL**  
Engineering  
Limited



## **MONDEL MEANS BRAKES**

### **MONDEL BRAKETRONIC CONTROL UNIT**

- Variable Frequency Torque Control
- Foot Pedal, Radio Remote Control or Ramping
- DC, AC-Single Phase or 3 Phase
- Replaces new or existing hydraulic systems
- Operates Multiple Brake Units
- General Purpose or Mill Duty Applications

# Mondel Braketronic Controller



## APPLICATIONS

THE MONDEL BRAKETRONIC CONTROLLER PROVIDES VARIABLE TORQUE CONTROL OF MONDEL THRUSTER OPERATED SHOE OR DISC BRAKES.

BRAKETRONIC CONTROLLERS CAN BE APPLIED TO SINGLE OR MULTIPLE BRAKE SYSTEMS AND CAN BE SUPPLIED FROM DC, SINGLE PHASE OR THREE PHASE POWER SUPPLIES AT ANY VOLTAGE OR FREQUENCY.

THE TYPICAL BRAKETRONIC CONTROLLER CAN OPERATE IN CONJUNCTION WITH A FOOT PEDAL OR MASTER SWITCH LOCATED TO DELIVER PROPORTIONAL CONTROL OF THE BRAKES.

IN LESS DEMANDING APPLICATIONS THE BRAKETRONIC CAN BE PROGRAMMED TO APPLY THE BRAKES AT A PREDETERMINED RATE BY MEANS OF "RAMP DOWN" USING A SINGLE STEP DEVICE IN THE RADIO TRANSMITTER OR PENDANT.

COMMAND CAN BE ARRANGED FOR REMOTE RADIO CONTROL OR SELECTED TO OPERATE FROM EITHER CAB OR RADIO THROUGH THE COMMAND TRANSFER SWITCH.

MONDEL BRAKETRONIC CONTROLLERS AND BRAKE SYSTEMS ARE REPLACING HIGH MAINTENANCE POWER ASSISTED AIR OVER HYDRAULIC SYSTEMS.

MONDEL HAS APPLIED BRAKETRONIC SYSTEMS ON A WIDE VARIETY OF INDOOR AND OUTDOOR CRANES. THESE CAN BE FOUND IN STEEL MILLS, FOUNDRIES, ALUMINUM SMELTERS, COPPER REFINERIES, POWER GENERATION PLANTS (INCLUDING NUCLEAR), SHIPYARDS, ASSEMBLY SHOPS AND WAREHOUSES THROUGHOUT NORTH AMERICA. OTHER APPLICATIONS INCLUDE MOVEABLE LIFT BRIDGES, CONVEYORS, FANS, LOCKGATES AND MANY OTHER TYPES OF ROTATING MACHINERY.



# Mondel Braketronic Controller



## SYSTEM FEATURES

- PROVIDES STATE-OF-THE-ART SOPHISTICATED BRAKING FOR CRANE TRAVEL MOTIONS COMPATIBLE WITH MODERN DRIVE TECHNOLOGY.
- OPERATES FROM DC, SINGLE PHASE, OR THREE PHASE, POWER.
- CAN BE PROPORTIONALLY CONTROLLED DIRECT FROM THE CRANE CAB OR VIA REMOTE CONTROL.
- CAN BE GRADUALLY APPLIED BY MEANS OF PRE-PROGRAMMED RAMPING USING SINGLE STEP CONTROL DEVICES.
- PERMITS THE USE OF CONTROL DEVICES WHICH ARE COMPATIBLE WITH MODERN ERGONOMIC SIT-DOWN CAB ARRANGEMENTS INCLUDING ROTATING CONSOLES.
- REPLACES STRAIGHT HYDRAULIC OR POWER ASSISTED BRAKING SYSTEMS, AND PROVIDES PARKING AND LOSS OF POWER EMERGENCY FAIL SAFE BRAKING.
- CAN BE RAMPED OR PROPORTIONALLY CONTROLLED FROM A SELECTED COMMAND SOURCE AND TRANSFERRED TO A RAMPED OR PROPORTIONALLY CONTROLLED ALTERNATE COMMAND SOURCE, OR VICE VERSA.
- PROVIDES THE ABILITY TO INTERLOCK WITH THE DRIVE TO PREVENT SIMULTANEOUS BRAKING WHILE THE DRIVE IS OPERATING.
- CAN BE PREPROGRAMMED TO SUIT YOUR REQUIREMENTS OR FIELD TAILORED TO ACCOMMODATE REVISIONS.
- CUSTOM ENGINEERING TO SUIT YOUR APPLICATION.
- NEMA 4 ENCLOSURE STANDARD.



# Mondel Braketronic Controller

## OPTIONAL FEATURES

- SPACE HEATERS FOR LOW AMBIENT APPLICATIONS.
- FACTORY TRAINING.
- PROGRAMMER AVAILABLE

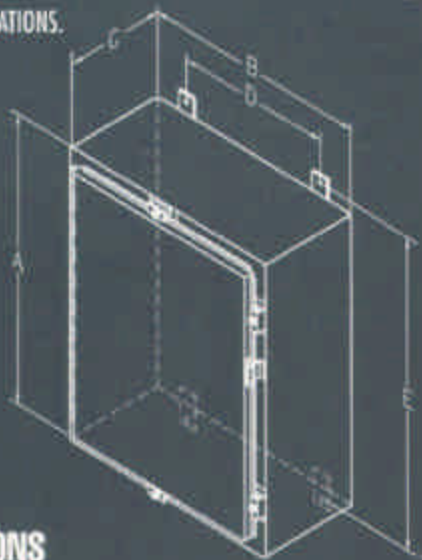

## NEMA 4 ENCLOSURE DIMENSIONS

TYPE	A	B	C	D	E	MOUNTING HOLES
P-230	20"	16"	8"	11"	21 - 1/4"	4 X 3/8"
P-400	20"	16"	10"	11"	21 - 1/4"	4 X 3/8"

## NEMA 4 - PEDAL DIMENSIONS

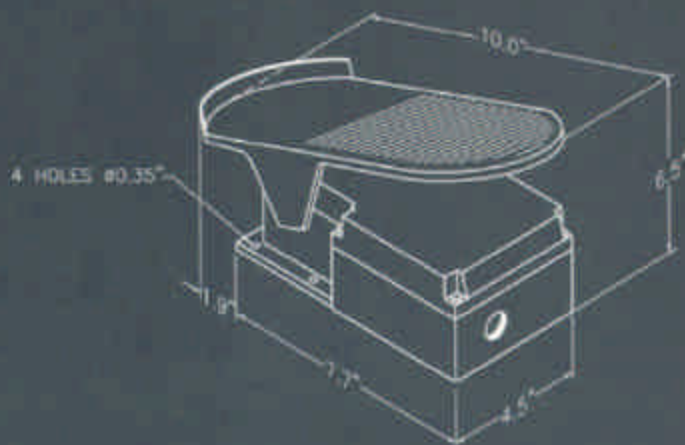

## MONDEL Engineering Limited

2610 Dunwin Drive,  
Mississauga, Ontario  
Canada L5L 1J5

Tel: (905) 828-1526  
Fax: (905) 828-5707  
1 (800) 792-7253

## MONDEL Limited

600 Bursca Drive,  
Suite 601, Bridgeville,  
PA, U.S.A. 15017

Tel: (412) 257-3565  
Fax: (412) 257-3567  
1 (800) 792-7253