

W22

Three Phase Motor

- Energy saving
- Increased productivity
- Extended lifetime
- Lower maintenance

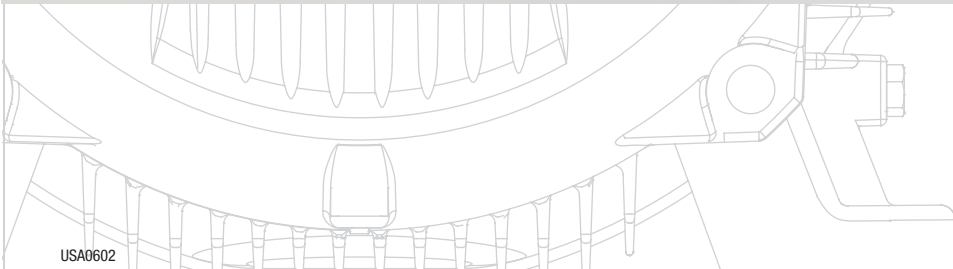

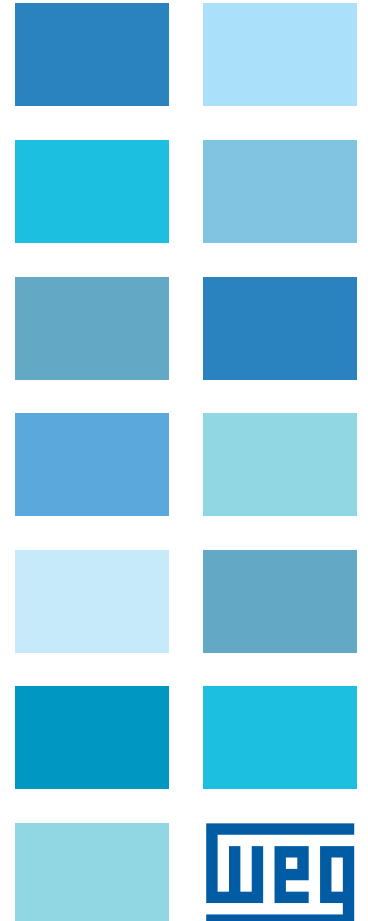
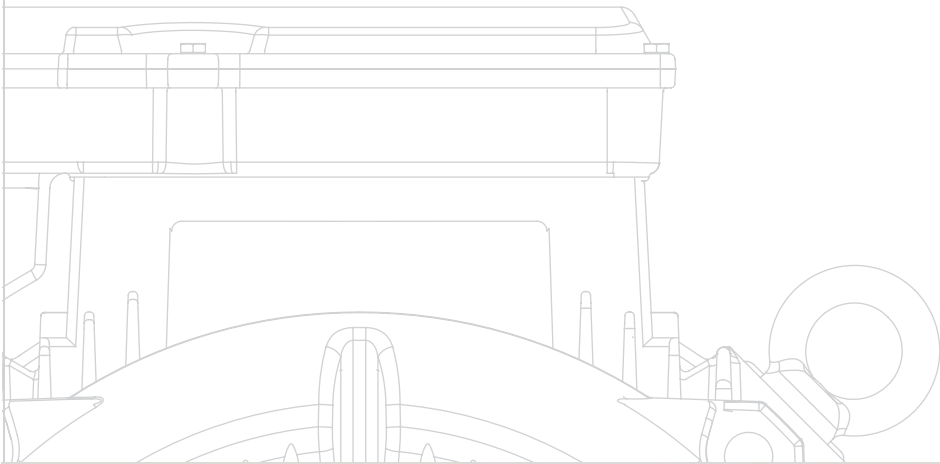

W22

Efficiency and reliability for industry

High performance with maximum energy efficiency is the goal of the new WEG electric motor. High efficiency and Low cost of Ownership throughout the entire motor lifetime have been the basis for the W22 development. A design created to maximize performance and energy savings.



NEMA 143T-587 and IEC 100-355M/L

W22, a new concept:

- Excellent cost benefit ratio
- Optimization of energy resources
- Updated electrical features
- Noise level reduction
- Vibration level reduction
- Easier maintenance

Lower total operational costs

A product that can operate most of its designed lifetime consuming the minimum possible energy, with high levels of reliability, generating the maximum value to the user – this is what is behind W22 new concept.

Inverter Duty applications

The exclusive WISE insulation system used on the W22 increases winding dielectric resistance, thus allowing VFD operation up to 575V without requiring further modification, resulting in flexibility and extended motor lifetime.

* Voltages above 575 V, please contact our nearest sales office.

Built to last

W22 motors are built using high quality FC-200 cast iron from WEG's own foundries, assuring maximum durability and high performance in aggressive conditions. The new fan cover design provides great impact resistance. Additionally the endshields have been designed for a better bearing heat dissipation and structural rigidity. Protected by our WEG coatings high performance paint system capable of passing a 240hr ASTM 117B salt fog chamber test.

Range extensions for the future

Available as both NEMA and IEC standards. The W22 line, offering high efficiency and low lifetime costs, will be the basis for further WEG developments.

Energy saving

Costs of energy correspond to approximately 90% of total operational costs throughout a motors lifetime. Acquisition, installation and maintenance cost are the other 10%. W22 new industrial motor platform is available with NEMA Premium® efficiencies, guaranteeing energy savings and reduced payback time.

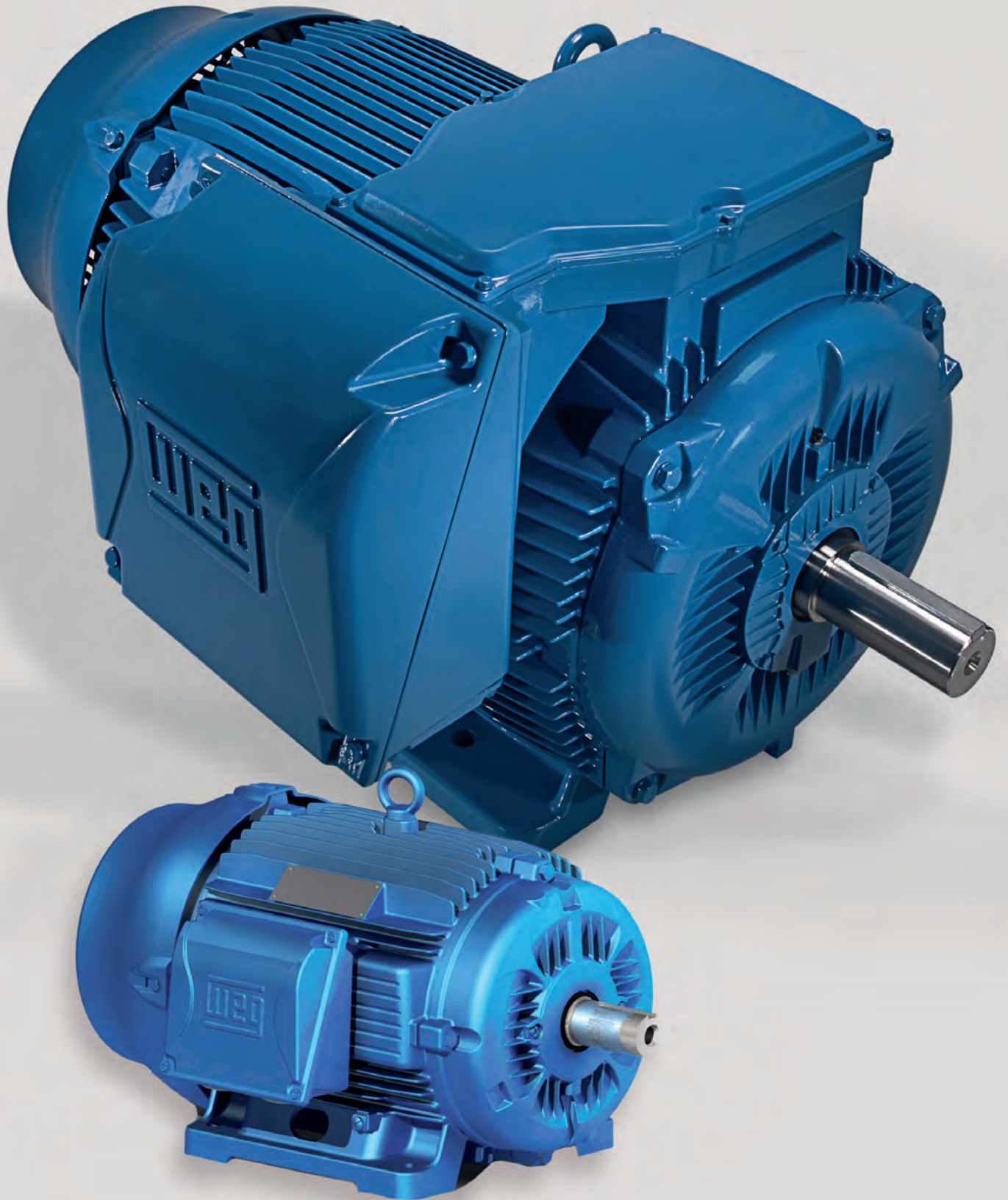

Aerodynamic design to increase airflow in all motor frames

Components Design

New Cooling System

Fan Cover

- Aerodynamic design
- Noise level reduction
- Better air flow distribution over frame
- Increased mechanical strength

Fan

- Reinforced fan hub structure
- Noise level reduction
- Increased air flow
- Fan with higher stiffness

Frame

- Terminal box position outlet on top 447T and larger
- Reduced temperature on windings and bearings
- Noise level reduction

Pad for vibration sensor

- Displaced 90° from each other

Enhanced Lifting Provisions

- Easier handling - horizontal & vertical
- Higher mechanical strength and handling safety

Solid feet

- More impact resistance
- Ideal for high vibration level applications

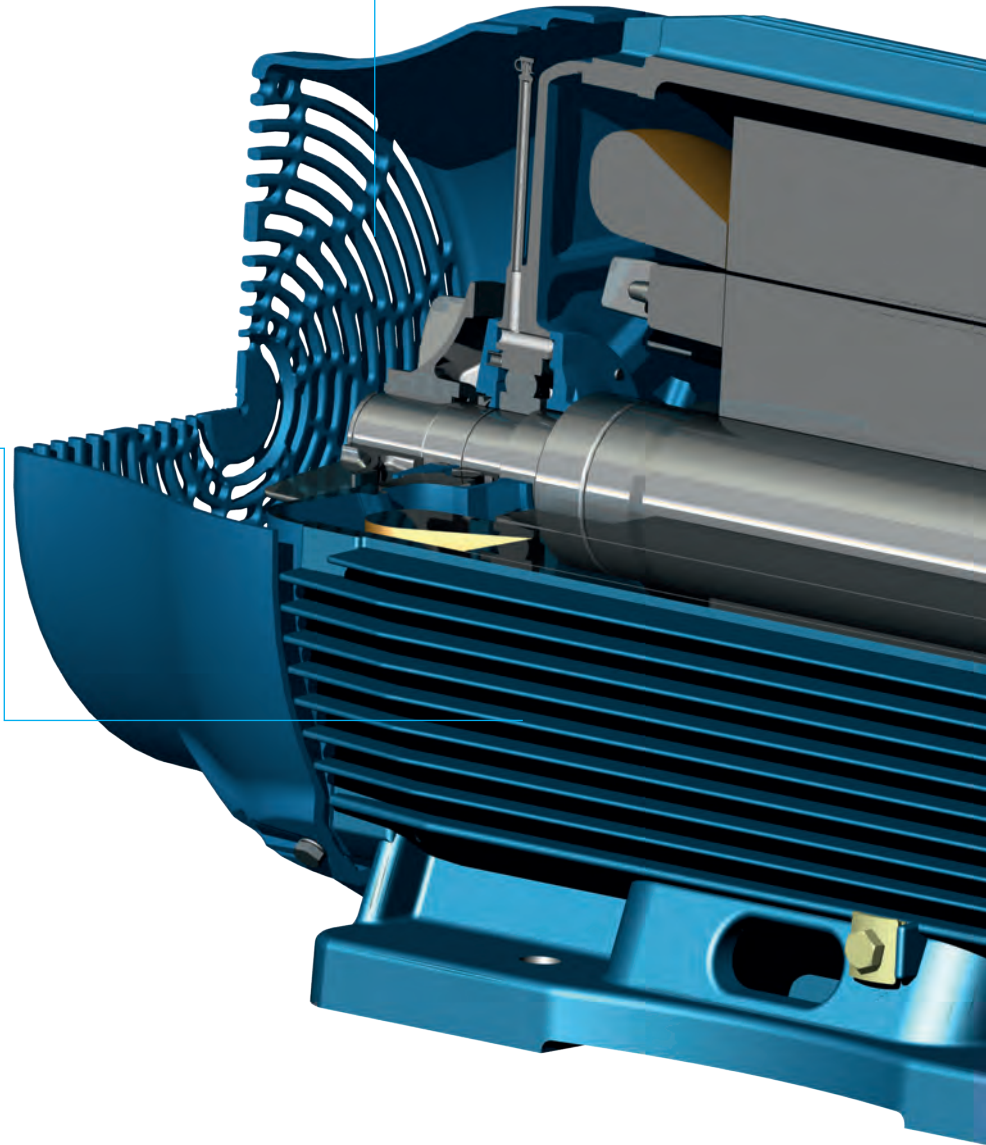

Endshields Subsystem

DE (Drive Endshield)

- New fin design
- Bearing moved outwards for better load support
- Improved bearing heat dissipation for reduced bearing temperature
- Reinforced endshield structure

NDE (Non-Drive Endshield)

- New design with smooth exterior surface
- Improved air flow
- Noise level reduction
- Improved structural rigidity for low vibration

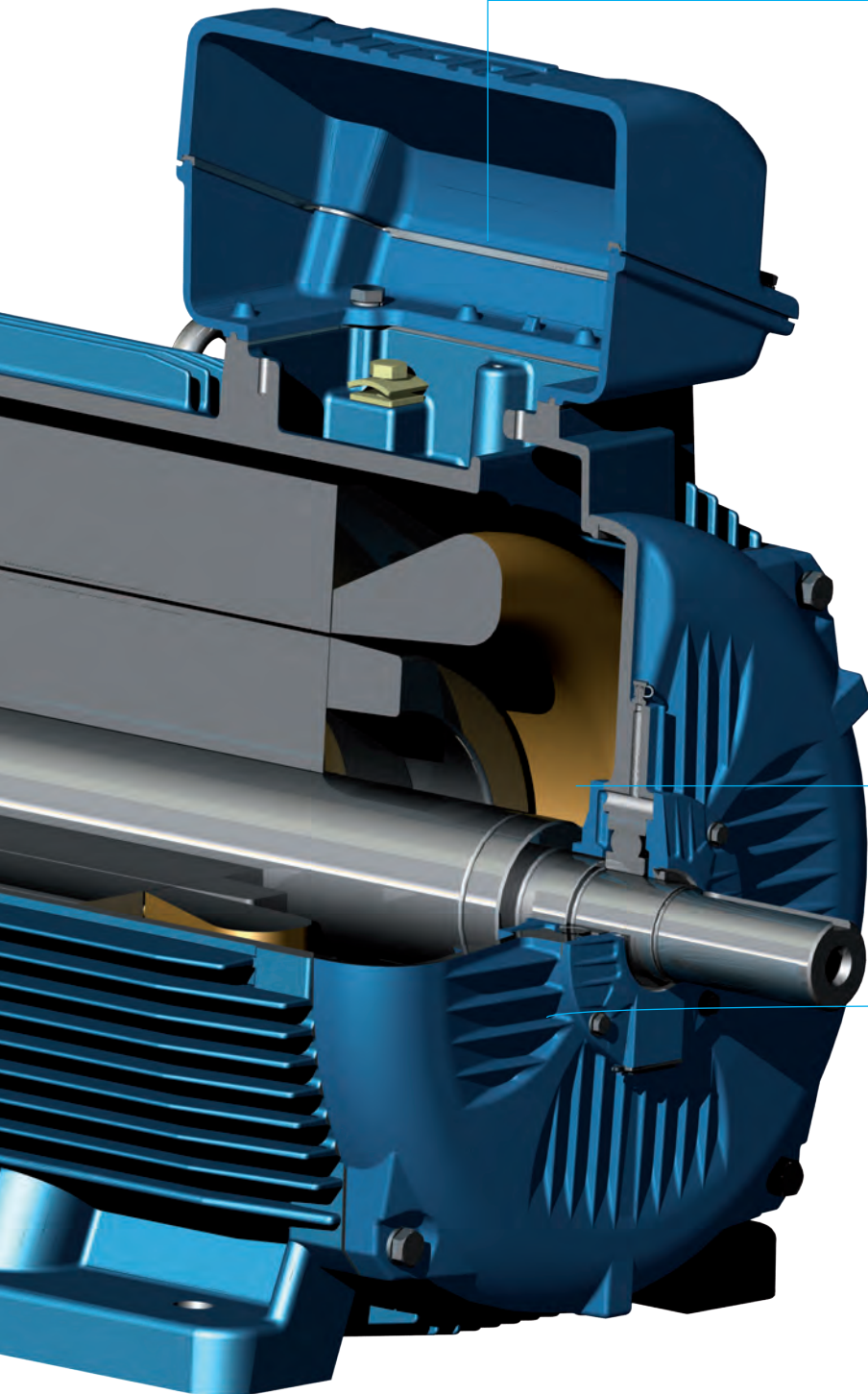

Terminal Box

- Better connection quality
- Easier cable handling during installation
- More space available for accessory installation
- Easier Maintenance
- Mounting F1/F2
- F3 Mounting optional on $\leq 445T$
- F3 Mounting field modifiable 447T and larger
- Rotation on 90° stages

Bearing Caps

External

- Finned surface for improved bearing heat dissipation

Internal

- Change of grease path for positive lubrication
- Bearing lubrication quality improvement
- Reduced bearing temperature

Seal Subsystem

- Increased dust and moisture protection
- Increased protection to high-pressure cleaning



Design Details

New cooling system

Redesigned to provide improved air flow through all motor frames keeping low operational temperatures and assuring reliability and extended lifetime. The aerodynamic design of the fan cover increases effective airflow, thus minimizing losses due to the recirculation of air between fan and fan cover. The fan was designed to provide strength and reduced noise level. Motor terminal box and eyebolts were repositioned on larger frames to allow better airflow. The new W22 cooling system also contributes to:

- Cooler bearing temperature extending relubrication intervals.
- Lower Noise Level fulfilling the most demanding Health & Safety regulations.
- Lower Overall Operational Temperature resulting in longer life.



Terminal box

Increased internal space making connections more accessible to the user resulting in an easier cable handling and connection.

Terminal box can be mounted on top, left or right side of the motor using the same frame on the 447T and larger motors. Top mounting is optional on smaller frames.

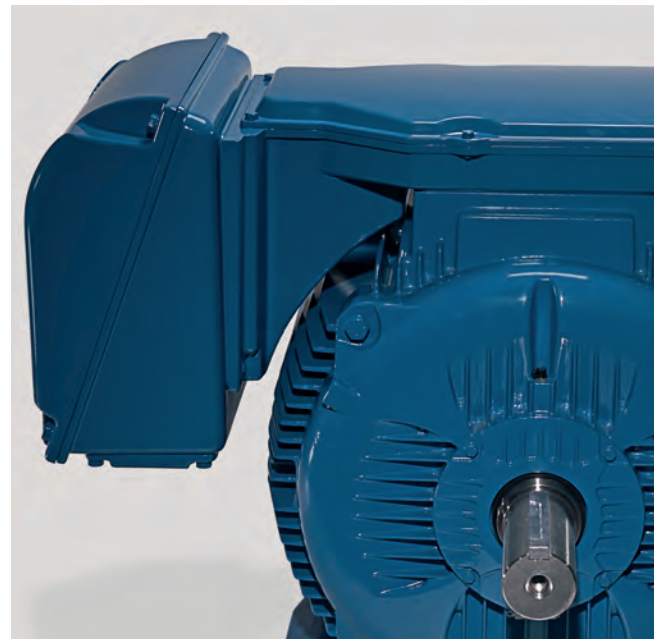

Frame

Motor feet are solid providing a more resistant structure against vibration. The frame design has points that can be used as provisions for vibration sensors as a standard feature.

Benefits from the new frame design:

- Motor temperature reduction
- Eyebolts repositioned - easier handling in the application.
- Provision for vibration sensors - frame and endshields with provisions 90° displaced according to maintenance technical recommendations. Easier and more reliable vibration analysis.
- Solid feet - Enhanced reliability when operating on high vibration applications and also provide easier alignment on installation.

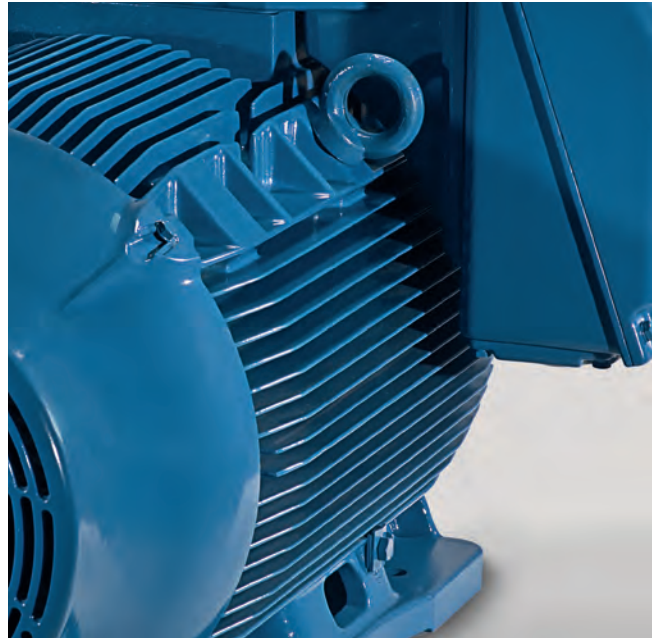

Exclusive bearing sealing system

Extends motor lifetime when operating in aggressive environments by protecting the motor against water and dust guaranteeing proper degree of protection.

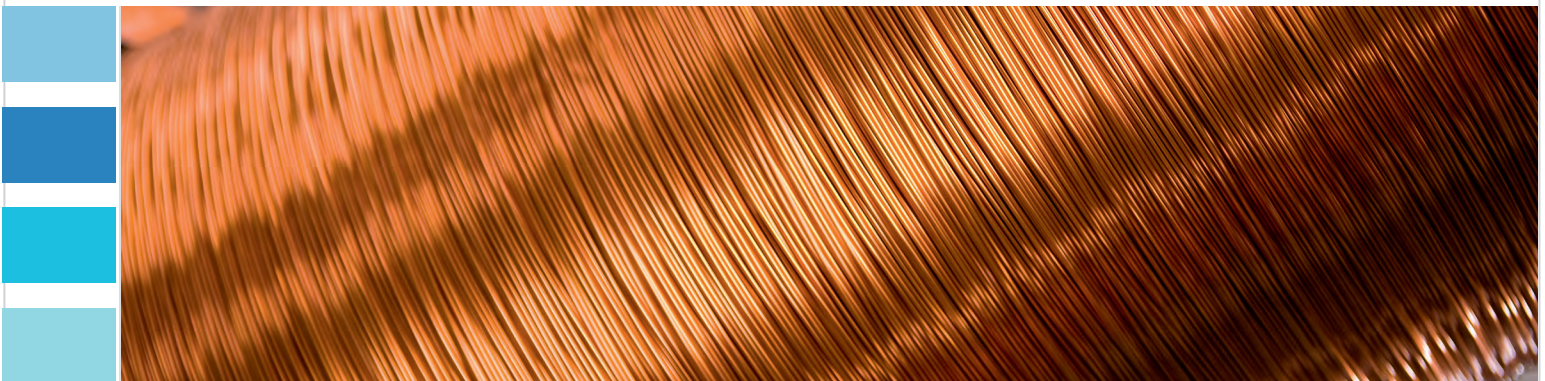



WEG Electric Corp.
1327 Northbrook Parkway, Suite 490
Suwanee, GA 30024
Phone: 1-800-ASK-4WEG
web: www.weg.net

Please contact your authorized distributor: