

NOTE 1: FILL TO LOWER RIM OF FILLER HOLE. USE ONLY FLUID IDENTIFIED ON THE ACTUATOR NAMEPLATE. DO NOT OVER-FILL.

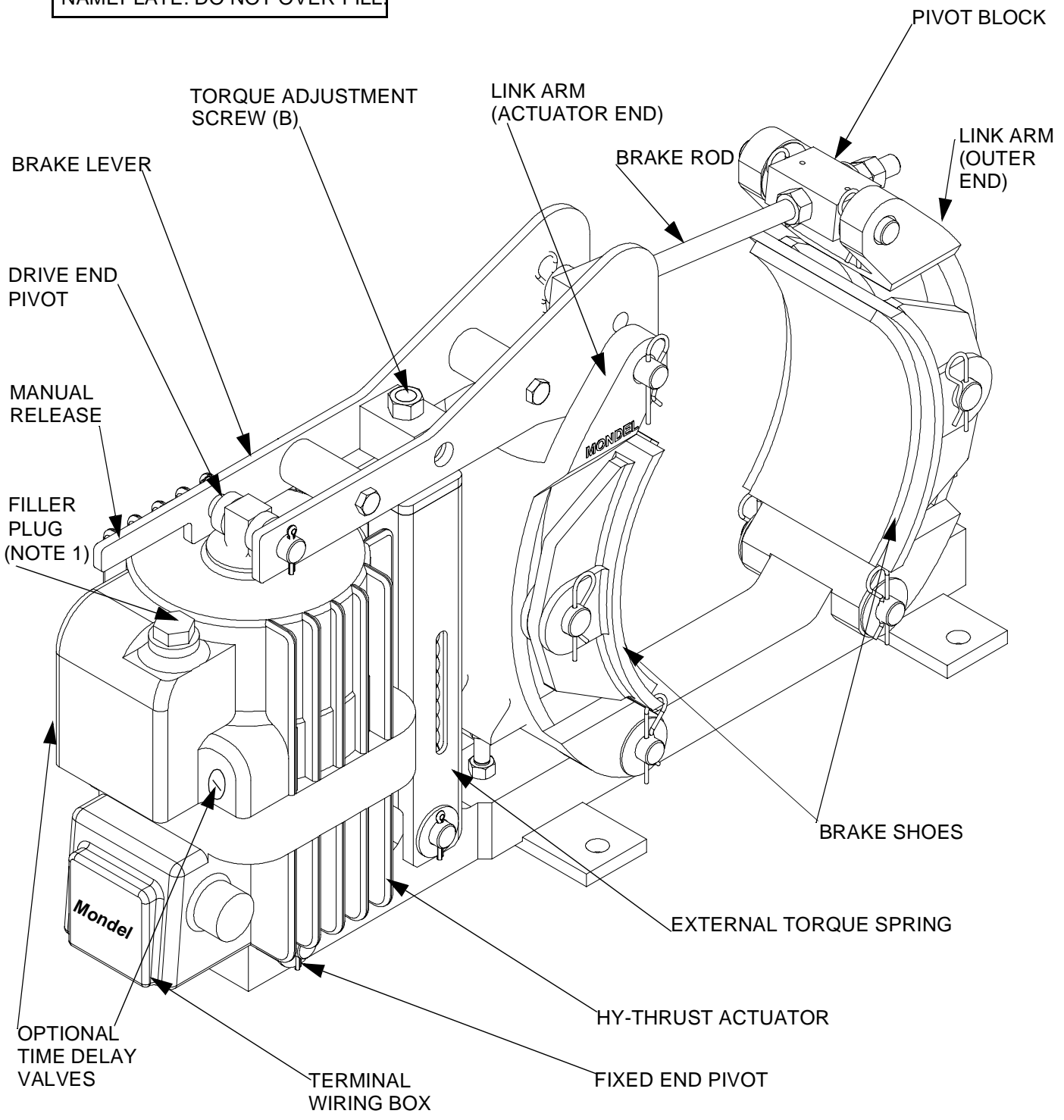



Figure 1: General Arrangement



Read And Understand All Warnings And Notices Printed In This Manual Before Commencing Installation, Adjustment, Test Or Repair.

1.0: Contents

Contents 3
 General Description 3
 Application 4
 Description of Operation 4
 Installation 5
 Adjustment 7
 Electrical Detail 10
 Operational Test 11
 Maintenance & Repair 13
 Replacement Parts 17
 Long Term Storage 18

2.0: General Description

2.1: MONDEL type MST/E spring applied, Hy-Thrust actuated general purpose brakes are designed for use in industrial applications. They can be used with drives employed in hoisting or horizontal travel motions.

2.2: There are two basic models of this versatile, high-speed, AC operated brake: Type MST with a fixed value internal torque spring, and Type MST/E with an adjustable external torque spring.

2.3: The type MST brake spring is contained within the actuator. The brake can be arranged to deliver a percentage of the maximum torque by re-arranging the brake pivot pins to provide a different lever ratio.

2.4: The type MST/E has an external torque spring which is infinitely adjustable down to less than 50% of maximum torque.

2.5: Construction and operation of both models is similar; they are available for wheel sizes 6" to 19". A limited range of shunt-wound DC motor actuators is available.

2.6: A wide range of options is available ; consult factory.

2.7: When the load cycle requires a larger than normal size, as is frequently the case on crane bridge drives, type MST & MST/E brakes can be provided with torques lower than traditional for a given wheel size.

Except when specifically engineered and used in conjunction with MONDEL BRAKETRONIC CONTROLLERS, type MST/E are more suited to crane bridge brakes.

2.8: The type MST & MST/E brakes can be supplied as "drop-ins", with footprints and shaft heights to replace a wide range of competitors brakes, including some metric sizes.

2.9: The standard actuator is weatherproof and dust proof. The electric motor is TENV construction, and the hydraulic section is fully sealed and self contained. Electric motors for certain hazardous areas are available as options.

2.10: An optional breather unit can be installed to replace the standard filler plug for environments which experience large temperature swings. The breather prevents pressure build-up within the actuator.

2.11: For more demanding environments, special hardware, enclosures, paint and surface treatments are available.

IF YOU HAVE AN UNUSUAL APPLICATION, OR REQUIRE A RECOMMENDATION FOR A BRAKE SIZE AND TYPE CONTACT MONDEL ENGINEERING.

3.0: Application

3.1: The brake covered by this manual is type **MST/E**. This brake has an adjustable external torque spring and is generally applied on installations where the required torque cannot be pre-determined within well defined limits.

3.2: For a given wheel diameter the Association of Iron and Steel Engineers (AISE) determines the prescribed torque when applied to 30 and 60 minute rated motors in steel mill applications.

3.3: When applied to four quadrant drives, or other applications where wheel heating can be accurately predicted, type MST/E brakes can be provided with torque values in excess of the AISE recommendations.

3.4: When the load cycle requires a larger than normal wheel size, as is frequently the case on crane bridge drives, MST/E brakes can

be provided with torques lower than AISE for a given wheel size.

3.5: For applications where larger than normal running clearance is required, a larger actuator can be applied to a given brake. Typical would be severe applications where wheel expansion can be considerable or where excessive wheel run-out can be expected.

4.0: Description of Operation

4.1: The brake is spring applied & actuator released. A heavy-duty compression spring outside the actuator, pulls down on the brake lever and forces the shoes against the wheel.

4.2: The actuator piston rod extends when power is applied, the brake-shoe pressure removed and running shoe clearance established. (See Fig. 2).

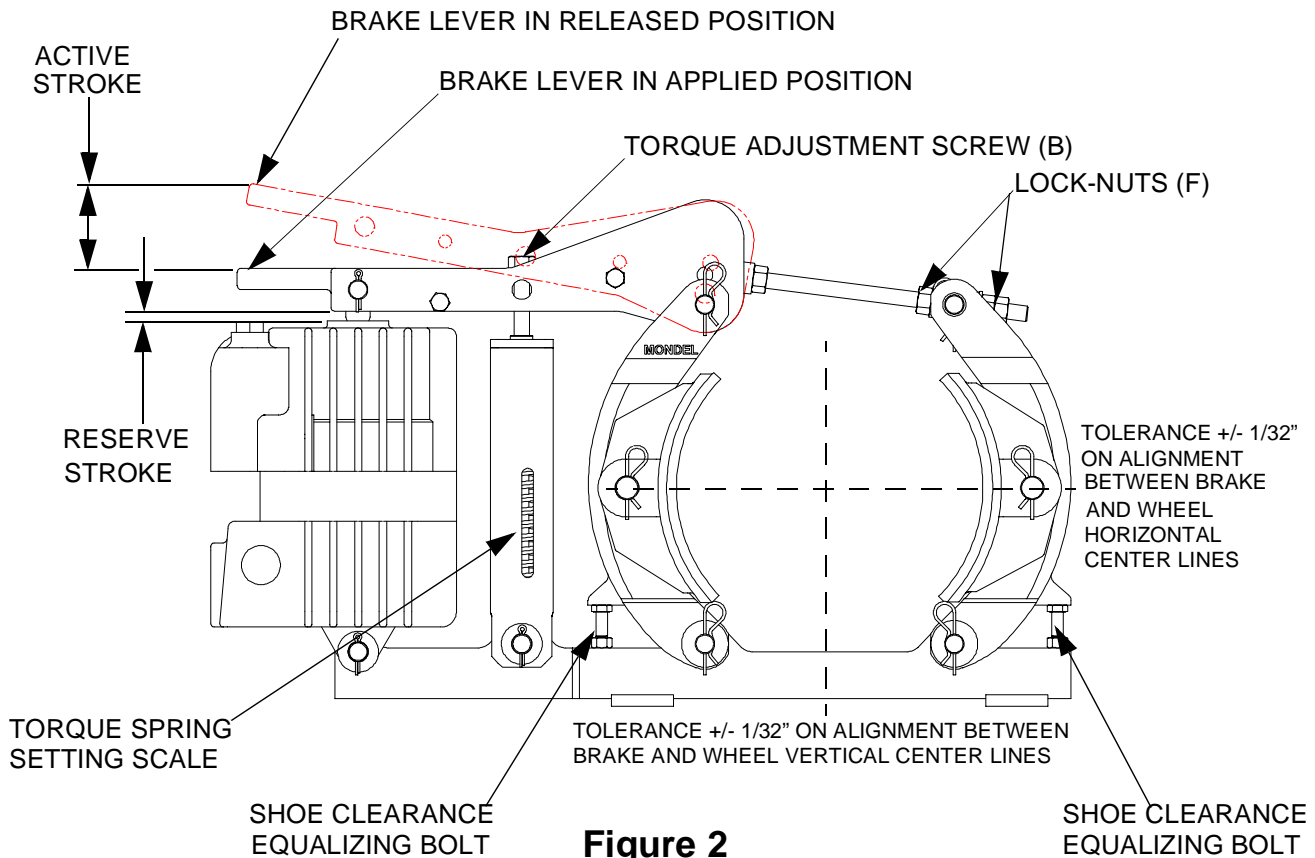

Figure 2

4.3: Subject to the effect of brake geometry, braking torque depends upon three major factors:

4.3.(a): The diameter of the wheel.

4.3.(b): The coefficient of friction of the lining material.

4.3.(c): The force with which the linings are applied to the wheel.

4.4: Power applied to the actuator cancels the brake's ability to apply torque.

4.5: The force with which the linings are applied to the wheel depends on the spring length and characteristics. Spring length increases as linings wear.

4.6: When the brake is released, manually set shoe clearance equalizing bolts ensure equal clearance between each shoe and the wheel.

4.7: Because the applied brake shoe force is proportional to the compressed length of the torque spring, a slight decrease in brake torque occurs as linings wear.

4.8: Adjusting the reserve stroke to its specified setting restores the required spring force.

NEMA states: "The torque ratings apply at a worn lining condition defined as the point where re-adjustment is required as recommended by the manufacturer."

4.9: To understand how shoe clearance is achieved it is important to recognize that the total available shoe clearance is directly related to the length of active stroke and that the actuator "Fully Released" position is the only consistent value for actuator stroke. The "Brake Applied" position varies as the linings wear resulting in a reduced "Reserve Stroke". The "Brake Applied" position also varies due to wheel expansion caused by temperature increase; this results in an increased "Reserve Stroke".

4.10: After significant lining wear - and the brake wheel has cooled to nearly ambient tem-

perature - a reduction in the "Reserve Stroke", with a corresponding increase in the "Active Stroke", will be noticed. Corrective action is necessary to ensure the minimum reserve stroke. (See Section 6: "Actuator Stroke Adjustment").

4.11: Each time the brake is released, the shoes move apart to provide running clearance from the wheel. The actuator's active stroke and brake lever ratio establishes the total clearance available for both shoes. The clearance allocated to each shoe is determined by the setting of the "shoe clearance equalizing bolts". See Fig. 2 and Section 6: "Shoe Clearance Adjustment".

4.12: This series of MONDEL Brakes is equipped with self-aligning, parallel clearance shoes which are designed to allow greater tolerance of wheel run-out and similar problems.

4.13: Various optional features are available, including latching hand release mechanisms, limit switches, hydraulic and pneumatic overrides, etc. If the brake covered by this manual has any of the optional features, they will be listed on the front page of this manual and covered by supplementary instructions.

4.14: The actuator for this series of MONDEL Brakes can be supplied with optional, factory installed time delays.

5.0: Installation





Anyone involved in the installation or service of this brake must have:-

- received specific training.
- had experience on similar equipment.
- knowledge of the equipment on which the brake is installed.
- the ability to understand the terminology.
- the ability to understand the diagrams.

Do not proceed unless technically qualified for the work involved.

5.1: After unpacking, visually inspect the brake assembly to ensure that damage has not occurred during shipment and that there are no loose or missing parts.

 **Never lift the brake assembly by the brake rod. The weight of the brake can irreversibly damage the rod leading to fracture and total loss of braking effect.**

 **The integrity of the brake may be compromised or a replacement part may not fit if alterations are made to the brake to achieve required alignment.**

 **If alterations to the brake supporting structure are required, they must be done under the direction of a competent authority.**

 **All electrical power to this equipment must be disconnected by competent personnel. Consult specific wiring diagrams to identify and isolate all live power inputs to the equipment.**

 **Unexpected movement or hazardous voltage can cause injury or death. Disconnect, lock out, and tag out the power source that feeds this device to prevent power from being applied while inspection and repairs are being performed. Before beginning repairs, try the operational controls to verify that the intended power source is disconnected.**

 **On a hoist, chock the drum to prevent any rotation due to the effect of gravity on the hook block etc.**

 **On a travel motion subject to the effect of wind or camber gradient, apply the wind anchors or otherwise secure the equipment against inadvertent movement when the brake is being worked on or is removed entirely.**

 **Failure to install the brake wheel correctly may result in total loss of braking. Do not operate the brake unless the wheel is secured to the shaft.**

5.2: Prepare the brake support structure and Install the brake assembly subject to the following:

5.2.(a): Allow adequate clearance between the brake and adjacent obstructions to allow access for adjustment and maintenance. **Brake shoe replacement requires space for complete withdrawal of the link arm pivot pins.**

5.2.(b): Whether mounting a brake in a new or existing installation, the base mounting bolts need a reasonable clearance in the base mounting holes to allow the brake to be aligned for full contact between the brake linings and the wheel.

5.2.(c): Circumstances may determine the best order of installation for the brake and the wheel. This may be due to the available space or handling facilities on site; generally the wheel is installed first.

5.2.(d): Center the brake shoes across the width of the brake wheel. This avoids ridge formation and the possible creation of a dangerous situation as the linings wear.

5.3: Alternatively, it may be necessary to introduce the brake to the brake wheel from one side of the wheel. In this case partial dismantling of the brake may be required depending on the circumstances. refer to the general arrangement and exploded view drawings in this manual to evaluate the options.

5.3.(a): After installing the brake and wheel, make preliminary adjustments to apply sufficient shoe pressure to raise the actuator piston rod 1/2" above its fully retracted position. (Fig. 2).

5.3.(b): This will apply the brake at approximately rated torque, causing the brake to square itself to the wheel and maximize the

shoe contact area, providing the bolt hole clearance will permit.

5.3.(c): When the brake assembly is correctly aligned and clamped to the wheel, loosen each of the securing bolts in turn and verify clearance in the base mounting holes. This will ensure tolerance to allow minor adjustments to the brake alignment to accommodate future re-lined shoes.

5.3.(d): For the reason identified in the previous paragraph MONDEL does not recommend "Dowelling" or "Keeper Plates" to maintain alignment.

5.4: Type MST/E brakes are generally installed with the base horizontal and the brake wheel shaft horizontal.

5.5: In most applications the brake can be installed from one side of the brake wheel. Alternatively it may be necessary to partially dismantle the brake.

5.6: Type MST/E brakes can also be wall mounted, with the brake wheel shaft horizontal. This is only possible if the actuator pump suction is flooded, which will be the case if the actuator hydraulic section filler plug is at the highest point possible with the actuator horizontal. For this mounting arrangement the actuator is best located above the wheel. The equalizing bolt opposite the actuator will be most effective in ensuring equal shoe clearance.

5.7: Type MST/E brakes can also be wall mounted with the brake wheel shaft vertical. Again this requires the actuator hydraulic section filler plug to be at the highest point possible with the actuator horizontal. For this mounting arrangement both equalizing bolts may be required to ensure equal shoe clearance.

5.8: For any other mounting arrangements consult factory.

5.9: The brake assembly must always be square and aligned to the brake wheel within a

maximum of $\pm 1/32$ inch, in three axes (horizontal, vertical, and longitudinal), (Fig. 2).

5.9.(a): Adjust the brake support bracket to achieve the specified horizontal and longitudinal alignment. For best performance, the brake base should be flat and parallel to the wheel rim, or motor shaft. It may be necessary to release and re-apply the brake pressure several times to achieve optimum alignment. Shim under the brake base for the vertical alignment.

5.9.(b): When the brake assembly is correctly aligned and clamped to the wheel, check the securing bolt clearance in each of the in the brake base holes. There must be clearance in the base and through the brake support bracket to allow minor adjustments. Be sure that the brake shoes are still aligned parallel to the face of the brake and that each brake shoe is fully secured to its link arm.

5.9.(c): With the brake fully applied, verify that the shoes are centered on the wheel face and that lining contact is within adequate bedding range.

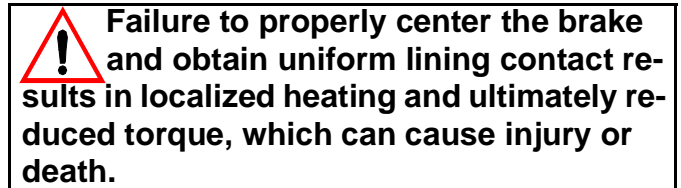

5.9.(d): When the brake is correctly aligned in all three axes, tighten the brake mounting bolts and re-check the alignment.

5.10: Connect the actuator to the electrical supply using a flexible, sealed conductor suitable for the rated temperature. Use type "S0", or higher temperature, cable. The actuator must be allowed a few degrees of movement without the risk of dirt or moisture entering the terminal box. Section 7 provides all necessary electrical details.

6.0: Adjustment

6.1: Following any adjustment or repair of the brake, test operation of the brake as described under “Operational Test”, Section 8.

6.2: Complete adjustment is required following any rework where any settings were disturbed.

 **Disconnect, lock out, and tag out the disconnect switch which feeds this equipment to prevent power from being applied while service is being performed.**

 **On a hoist, chock the drum to prevent any rotation due to the effect of gravity on the hook block etc.**

 **Protect against the possibility of movement due to the effects of gravity, wind or other energy source which has the potential to create a hazard when the brake is being worked on or is removed entirely.**

Table 1

BRAKE WHEEL SIZES (inches)	TYPICAL RUNNING CLEARANCE BETWEEN LINING AND BRAKE WHEEL (inches)	MAXIMUM FULL SPEED BRAKE WHEEL RUN-OUT (inches)
6	0.014	0.006
8	0.016	0.008
10	0.020	0.010
13	0.026	0.013
16	0.032	0.016
19	0.038	0.019

Notes:

1. Refer to “Brake Installation” and “Replacing the Brake Shoes” for adjustment instructions.
2. Evaluate brake wheel run-out at full speed. It must not exceed value shown in this table.

6.3: Manual Operation

6.3.(a): Brake installation, shoe replacement and actuator replacement, described elsewhere, require the brake to be released and re-applied without energizing the actuator. When

type “S” Latching Hand Release is fitted it can be used; otherwise apply the following alternative:

6.3.(b): To manually release the brake: Adjust the brake rod hex-nuts, (See Fig.2) - to increase the brake rod length - reducing the “reserve stroke” until the piston rod is no longer visible. Continue adjustment until there is sufficient lining to brake wheel clearance.

6.3.(c): To manually apply the brake: Adjust the brake rod hex-nuts, (See Fig.2) - to decrease the brake rod length - increasing the “reserve stroke” until the linings contact the brake wheel. Continue until the brake release lever begins to rise then proceed to “Actuator Stroke Adjustment”.

6.4: Actuator Stroke Adjustment

6.4.(a): When power is applied to the actuator the piston will be caused to extend. This will compress the spring and raise the brake lever to provide operating clearance between the shoes and the wheel.

6.4.(b): When power is removed from the actuator, the spring will retract the lever until the shoe pressure on the wheel prevents any further lever movement as the reserve stroke setting is attained and the intended brake torque achieved.

6.4.(c): Adjust the brake rod hex-nuts, (Fig. 2), until the brake release lever raises the piston rod to the specified reserve stroke, (Table 2). Re-secure the brake rod nuts against the pivot block.

 **Monitor the brake and do not allow the actuator “reserve stroke” to fall below 25% of full stroke.**

 **An actuator reserve stroke of zero will result in total loss of brake**

 **Under no circumstances should the brake be allowed to function with zero reserve stroke. Such operation results in loss of load control, which can result in injury or death.**

Table 2

ACTUATOR	MAX STROKE (inches)	ACTIVE STROKE (inches)	DESIRED RESERVE STROKE (inches)
Ed12/4	1.57	0.97	0.6
Ed23/5	1.97	1.27	0.7
Ed30/5	1.97	1.27	0.7
Ed50/6	2.36	1.56	0.8
Ed80/6	2.36	1.56	0.8
Ed121/6	2.36	1.56	0.8

6.5: Torque Adjustment

6.5.(a): The rated torque, as shown on the nameplate, will be developed when the following conditions are met:-

6.5.(a).(i):The brake is applied and aligned properly.

6.5.(a).(ii):The actuator stroke is correct.

6.5.(a).(iii):The correct linings are fitted.

6.5.(a).(iv):The linings are in good condition and bedding is completed.

6.5.(a).(v):The brake wheel is aligned and in good condition.

6.5.(b): Torque adjustment for Mondel **MST/E** brakes is adjustable on site. Tighten or loosen screw (B), see Fig. 2, to set the torque within the prescribed range shown on the scale. The torque setting is obtained by matching the top of the spring-block to a line on the spring scale.

6.6: Shoe Clearance Adjustment

6.6.(a): The total available shoe clearance is determined by the active stroke of the actuator and the brake lever ratio. Distribution of the re-

sulting clearance is determined by the setting of the active shoe clearance equalizing bolt. (Fig. 2).

6.6.(b): Generally only one of the two equalizing bolts will be effective depending on the lever ratio arrangement and subject to the brake being installed horizontally or vertically.

6.6.(c): The “active” equalizing bolt will be evident after energizing the actuator.

6.6.(d): To equalize the brake shoe running clearance:

6.6.(d).(i):Back-off both equalizing bolts and energize the actuator allowing the shoes to move away from the wheel.

6.6.(d).(ii): Adjust the active side equalizing bolt to limit the travel of that shoe; this moves the other shoe away from the wheel. Continue adjustment until wheel clearance is equal for both shoes.

6.6.(d).(iii):Set the non-active side equalizing bolt so that shoe travel is not restricted; lock both equalizing bolts with jam-nuts.

6.7: Parallel Shoe Gap Adjustment

6.7.(a): For optimum lining wear distribution, brake shoes have controlled freedom to align with the wheel contour as the linings wear.

6.7.(b): Each brake shoe holder pivots on its link arm. Its freedom to rotate under gravity is controlled by a shoe holder friction mechanism.

6.7.(c): Spring loaded pins in each link arm bear against the inside of the shoe; see Fig. 3. This provides tension to maintain shoe alignment when the brake is released. The tension is not adjustable. When a shoe is replaced make sure that both shoe alignment tension mechanisms are re-installed.

6.7.(d): To align shoes with the wheel, apply the brake at the rated torque and make the following initial adjustments:

6.7.(d).(i):Release the brake manually or under power.

6.7.(d).(ii):With the brake released, use a soft-faced mallet to tap the upper edge of each brake shoe in towards the wheel in the direction it would rotate under gravity.

6.7.(d).(iii):Re-apply the brake and the shoes will be forced to align with the wheel to optimize parallel clearance with the wheel.

6.8.(a).(iv):When time delay valves are not fitted, the actuator response time to extend or retract, is between 0.4 and 0.8 second depending on actuator size.

6.9: With time delay valve(s) installed, the extend and/or retract times are adjustable between approximately 0.5 and 10 seconds depending on actuator size.

6.9.(a): Remove the delay valve protective cap to expose the adjustment screw. For minimum delay set the screw head flush with the housing. Figs. 1 and 2 show valve location.

6.9.(a).(i):Turn the screw clockwise to increase, and counter clockwise to decrease the delay.

Note: The standard actuator has the shortest response time. An actuator fitted with delay(s) provides longer response times, even when the delay(s) are adjusted for minimum effect.

! To prevent entry of contaminants, replace adjustment screw caps once adjustments are complete.

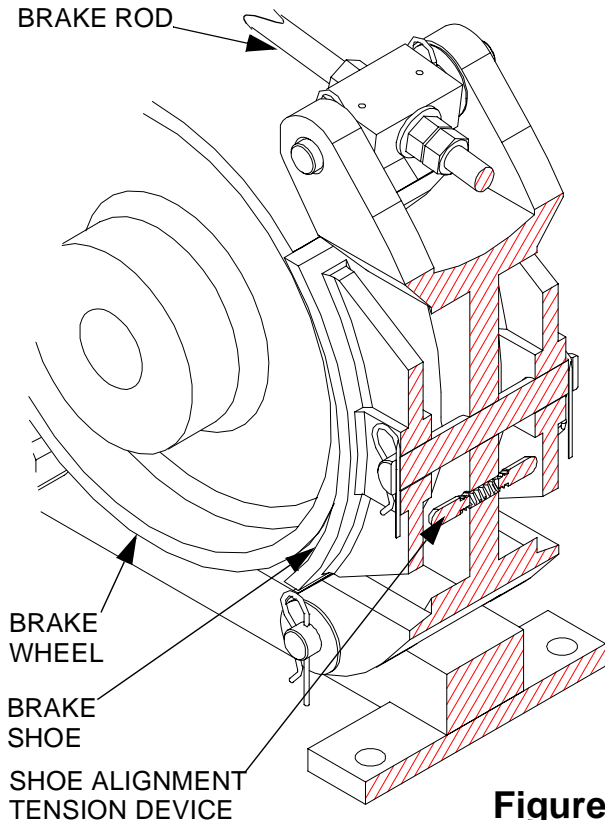

Figure 3

SECTION THROUGH SHOE AND LINK ARM
DRAWN TO REVEAL TENSION DEVICE

6.8: Time delay adjustment

6.8.(a): The actuator nameplate will indicate when optional time delay valves are installed.

6.8.(a).(i):Letter “S” indicates an adjustable piston retract, (brake application), time delay.

6.8.(a).(ii):Letter “H” indicates an adjustable piston extend, (brake release), time delay.

6.8.(a).(iii):If both letters “S” and “H” are present, then the actuator is equipped with adjustable time delay valves independently controlling both the piston extend and retract times.

7.0: Electrical Detail

7.1: Operation of the actuator is not dependent of the direction of motor rotation. The cable leads can be connected to the U1, V1 and W1, (T1, T2, T3), terminals in any phase sequence.

7.2: The motor leaves the factory already arranged for the specified voltage which is also shown on the nameplate.

7.3: If the motor was specified for a nominal 460 volts supply, it will be connected with nine terminals and the links arranged as shown in Fig. 4. If at some future date the motor is required to operate from a 230 volts supply, re-arrangement of the links is required as shown.

7.4: When specified for operation on 575 Volts or other single voltage, it will be connected with six terminals, the links arranged as

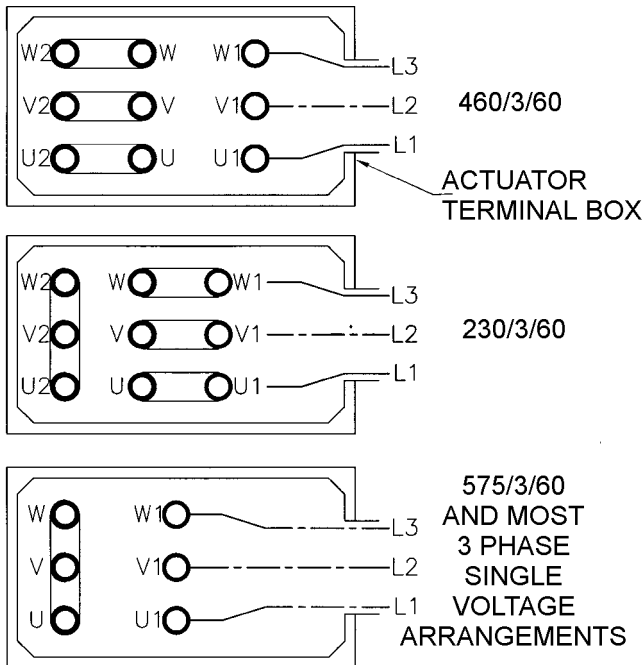

Figure 4 : Electrical Connections

shown in Fig. 4. The winding will not be capable of re-connection for any other voltage.

7.5: Explosion Proof actuators are only arranged for the terminal voltage shown on the nameplate. Three terminal posts will be visible when the cover plate is removed under the required conditions. No provision is made for external re-connection to any other voltage.

7.6: A wiring diagram showing the possible terminal link arrangements is fastened inside the actuator terminal box cover.

! The actuator motor must be connected to its supply through a flexible cable or sealed flexible conduit. This is required to ensure that contaminants will not enter the motor through the wiring and junction box.

! To avoid contact with “live” terminals and prevent the entry of contaminants replace the terminal box cover as soon as connections are complete.

8.0: Operational Test

! Always perform an operational test of the brake after any replacement, adjustment, or repair. Read and understand the intent of the warnings published in this document - if in doubt ask

! Before conducting an operational test, remove all tools, chocks and other equipment, which may create a hazard when the machine is operated.

! Following any repair or adjustment, and before conducting an operational test, verify that all brake adjustments are complete in accordance with section 6.

! In a hoist application, post observers to monitor the position of the hook if it travels out of sight of the operator.

! Before attempting to operate any motion in any application, advise and account for the location and security of all personnel involved.

8.1: Heed all warnings and notices in addition to the owners' safety procedures.

8.2: Follow all standards and local statutes.

8.3: Remove any drum chocks on a hoist application.

8.4: As a preliminary test of the brake without load, energize the actuator for one short jog. If the brake fails to stop and hold the motion stationary, repair or re-adjust the brake as necessary. Visually inspect the brake during operation to ensure all adjustments are correct. If successful, continue with longer duration jogs until confident that the brake is operating satisfactorily.

8.5: A minimum of 60% contact between lining and wheel on each shoe is required before subjecting the brake to its rated capacity.

8.6: If re-lined shoes have been fitted, or the brake alignment has been altered or is otherwise suspect, you may have to realign the brake. This will minimize the bedding needed to obtain the necessary 60% of brake lining to wheel contact.

8.7: The required lining contact is seldom achieved without “bedding”, but time spent to achieve satisfactory bedding will be rewarded with a considerably longer life for the lining.

8.8: Modern linings, although hard wearing, are difficult to “bed” when the area in contact with the wheel cannot support the heat energy transferred to the brake. As a result the linings will become “glazed” where in contact with the wheel. “Glazing” is the name applied to a condition where the lining has been heated beyond its working temperature range and is no longer capable of its designed coefficient of friction. “Glazing will seldom be removed by further braking operations as any increase in area of lining contact will immediately be glazed.

8.9: “Glazing” can be prevented by ensuring a minimum of 60% contact area before placing the brake in service.

8.10: On hoists, well spaced, short bursts of energy, such as an E.Stop at high speed with no load are best to achieve initial “bedding”. This will limit the energy input while the wheel is monitored for temperature.

8.11: A distinct advantage of the type MST/E brakes is that the actuator can be easily over-ridden while the drive is operating. This can be accomplished with a short length of pipe fitted over the “manual release lever extension”. See Figure 1. When circumstances permit, pressure can be applied to force the shoes against the wheel while the drive is operating. Care must be taken to achieve the minimum 60% contact between lining and wheel on each shoe without exceeding the maximum of 150° C.

8.12: Bedding is just as important when the brake is applied with a four quadrant drive, and not subjected to dynamic loading, except under emergency conditions.

8.13: The following are the key steps to satisfactory “bedding” to extend lining life.

8.13.(a): Use only genuine Mondel lined brake shoes. This will maintain specified brake performance and ensure that the braking torque is neither more nor less than the specified rating.

8.13.(a).(i): Linings thicker than the original equipment may result in contact with the wheel only at the tips.

8.13.(a).(ii): Linings thinner than the original equipment may result in contact with the wheel only across the middle and cause vibration during stops.

8.13.(b): Do not use re-lined shoes where the castings are damaged, worn or distorted.

8.13.(c): Square the brake to the wheel for optimum contact between the linings and the wheel.

8.13.(d): Type **MST/E** brakes utilize shoe clearance equalizing bolts to equalize brake shoe clearance; ensure that they are correctly adjusted in accordance with Section 6.

8.13.(e): Type **MST/E** brakes incorporate a mechanism to keep brake shoe clearance parallel to the wheel; ensure that it is correctly adjusted in accordance with Section 6.

8.14: Wheel run-out must be within the allowable tolerance; see Table 1. Any unnecessary lining drag will result in excessive heat in the wheel and lining deterioration.

8.15: Every operational test should include verification of brake wheel run-out as follows:

8.15.(a): At all speeds, verify that the linings are clear of the wheel. Take steps to correct wheel run-out, imbalance or the effects of critical speed.

8.15.(b): If necessary, check low speed brake wheel run-out as follows:

8.15.(c): Using a run-out gauge, verify that radial run-out does not exceed 0.001” per inch of brake wheel diameter. Refer to Table 1 for brake wheel run-out allowance. Bearing play can also be checked by lifting the brake wheel with a suitable lever while observing the dial gauge.

9.0: Maintenance & Repair

 **When replacing a brake wheel or associated drive line components on an existing installation, verify that the brake is centered with uniform lining contact as described under the topic “Brake Installation”. Incorrect repair or replacement can result in death or injury to personnel.**

9.1: Replacing the Brake Shoes

 **Unexpected movement or hazardous voltage can cause injury or death. Disconnect, lock out, and tag out the power source that feeds this device to prevent power from being applied while inspection and repairs are being performed. Before beginning repairs, try the operational controls to verify that the intended power source is disconnected.**

 **Disconnect, lock out, and tag out the disconnect switch which feeds this equipment to prevent power from being applied while service is being performed.**

 **On a travel motion subject to the effect of wind or camber gradient, apply the wind anchors or otherwise secure the equipment against inadvertent movement when the brake is being worked on or is removed entirely.**

 **On a hoist, chock the drum to prevent any rotation due to the effect of gravity on the hook block etc.**

9.1.(a): NEMA Standard ICS 9-1993, Part 1 recommends that brakes be fitted with new or re-lined shoes before the lining material is worn excessively. Refer to Table 4 for minimum thickness.

9.1.(b): Remove and reinstall the brake shoes - using a lifting device if necessary - as follows:

9.1.(b).(i): On a hoist lower the load to the floor and disconnect the load from the bottom block.

9.1.(b).(ii): Rest the bottom block on the floor or on a suitable support. Chock drum to prevent rotation of the drum.

9.1.(b).(iii): Refer to Figure 5.

9.1.(b).(iv): Manually release the brake as instructed in Section 6.

9.1.(b).(v): Remove cotter pin and withdraw the actuator drive end pivot pin.

9.1.(b).(vi): Remove hitch pin at the active upper end of each link arm; withdraw the pivot pins.

9.1.(b).(vii): Lift the brake rod and lever assembly clear of the brake body.

9.1.(b).(viii): Remove hitch pin at the fixed lower end of each link arm; withdraw the pivot pins.

9.1.(b).(ix): Lift out the link arm/brake shoe assemblies.

9.1.(b).(x): Remove hitch pins and withdraw the shoe pivot pins. Brake shoes can now be removed for service. To avoid loss, restrain the spring loaded shoe alignment tension device when removing a shoe.

9.1.(b).(xi): Before starting shoe installation, check that the braking surface of the wheel is clean and free from oil and grease.

9.1.(b).(xii): Next, verify that the lining surface will be true to the wheel when the shoe is in-

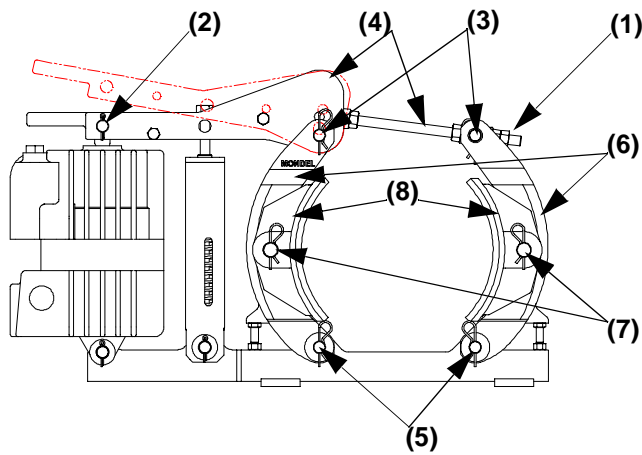

- (1) MANUALLY RELEASE BRAKE PER SECTION 6
- (2) REMOVE ACTUATOR DRIVE END PIVOT PIN
- (3) REMOVE LINK ARM UPPER PIVOT PINS
- (4) LIFT LEVER/ROD ASSEMBLY CLEAR
- (5) REMOVE LINK ARM LOWER END PIVOT PINS
- (6) LIFT OUT LINK ARM/SHOE ASSEMBLIES
- (7) REMOVE SHOE PIVOT PINS
- (8) REMOVE SHOES (SET ASIDE TENSION DEVICE)

Figure 5: Brake Shoe Removal

stalled. Carefully check lining contact with the wheel. Remove any high spots with emery paper to ensure 60% contact between the lining and the wheel.

- 9.1.(c): Ensure adequate clearance will be available and install the replacement shoe assemblies in the reverse order.
- 9.1.(d): Replace all pivot, cotter and hitch pins.
- 9.1.(e): Re-apply the brake and make all adjustments covered in Section 6.

NOTE: The brake can be damaged if the brake shoes are not properly aligned. Do not operate the brake unless the brake shoes are in their correct position and all shoe holder pivot and hitch pins are fully installed.

9.1.(f): Newly lined shoes seldom fit perfectly with the contour of an existing brake wheel, particularly if the wheel is worn or undersized. If the brake has been moved, realignment of the brake with the wheel may be necessary. Re-

fer to the topic “Brake Installation” for the correct alignment and bedding procedure.

Failure to properly center the brake and obtain uniform lining contact results in reduced torque, which can result in injury or death to personnel.

- 9.1.(g): Refer to Section 6 and adjust the reserve stroke as required.
- 9.1.(h): Refer to Section 6 and adjust the torque as required.
- 9.1.(i): Refer to Section 6 and adjust the brake shoe clearance as required.
- 9.1.(j): Refer to Section 8; bed and test the brake as described.

9.2: Removing The Actuator

- 9.2.(a): Secure against any possibility of an unexpected movement when the actuator is removed.
- 9.2.(b): Lower the load to the floor and disconnect the load from the bottom block.
- 9.2.(c): Rest the bottom block on the floor, or on a suitable support. Chock the drum to prevent rotation.

Unexpected movement or hazardous voltage can cause injury or death. Disconnect, lock out, and tag out the power source that feeds this device to prevent power from being applied while inspection and repairs are being performed. Before beginning repairs, try the operational controls to confirm the intended power source is disconnected.

- 9.2.(d): Disconnect and remove electrical wiring and conduit to the actuator
- 9.2.(e): Before attempting to remove the actuator release the brake. See Section 6: “Manually Releasing the Brake”.
- 9.2.(f): Secure or support the actuator before attempting to remove the pivot pins.

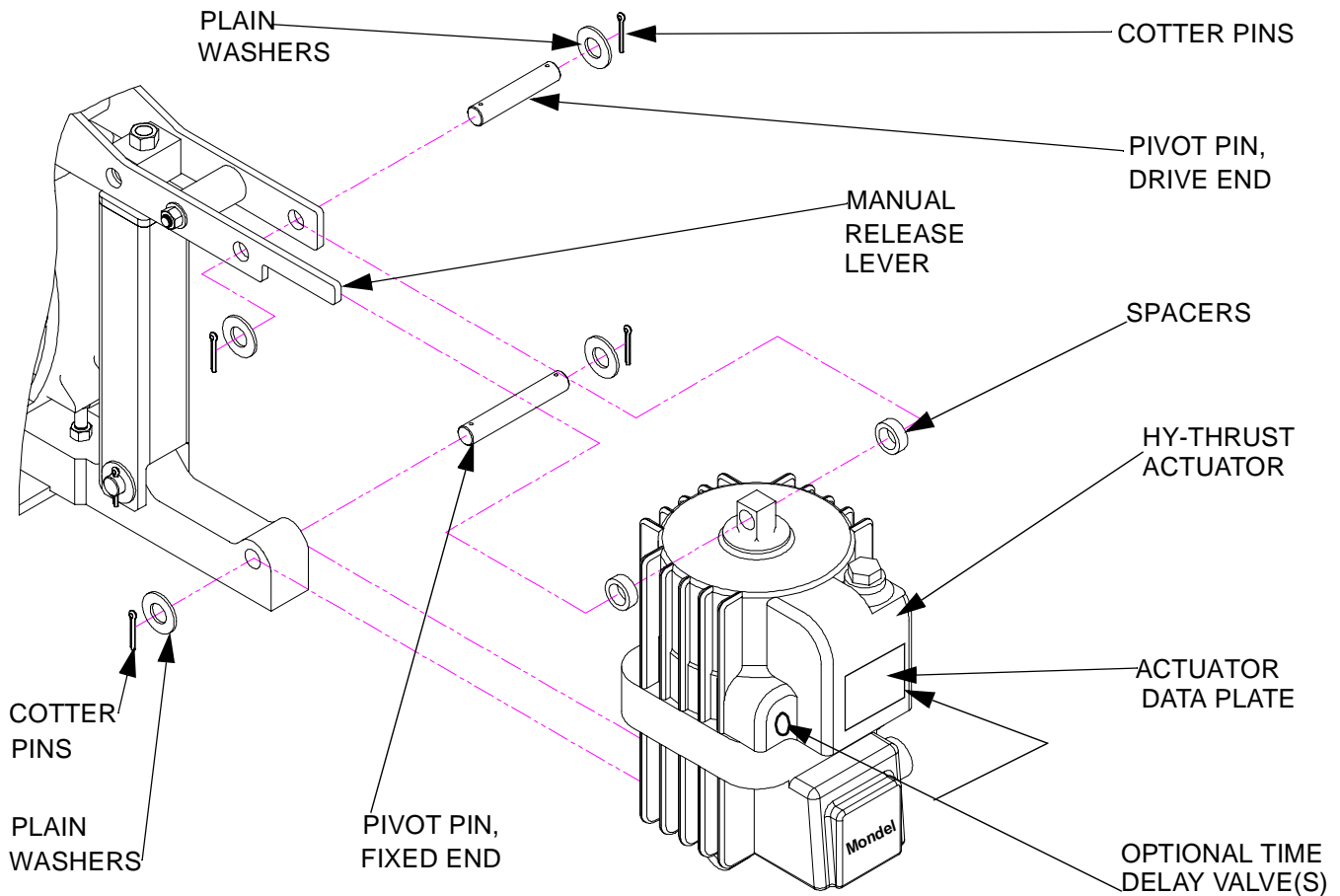

**Figure 6:
Actuator Removal and/or Replacement**

9.2.(g): Refer to Fig. 6: remove the cotter pins and withdraw the pivot pins attaching the actuator to the brake body.

9.2.(h): Remove the complete actuator using appropriate lifting devices.

9.2.(i): Should service be required, return the actuator to Mondel for repairs or service. Identify the actuator with the original brake serial number.

9.3: Re-Installing The Actuator

9.3.(a): Verify adequate means are still in place to protect unexpected movement when the actuator is replaced.

9.3.(b): Position the actuator within the lever and attach to the base. Use a lifting device as necessary

9.3.(c): Attach and secure the actuator using the correct pivot pins, etc. Check for wear prior to re-fitting. See Fig. 6.

9.3.(d): Refer to Section 6 and adjust the reserve stroke as required.

9.3.(e): Refer to Section 6 and adjust the torque as required.

9.3.(f): Refer to Section 6 and adjust the brake shoe clearance as required

9.3.(g): Re-connect the actuator wiring, as required, and replace the terminal box cover.

9.3.(h): Refer to Section 8; bed and test the brake as described.

9.4: Relining The Brake Shoes

It is not recommended that shoes be relined in the field. New bonded shoe assemblies can be ordered as repair parts. Factory re-

built shoes are also available from Mondel Engineering. Under this program, credit will be allowed for old shoes in usable condition.

9.5: Removal and Installation of Motor and Brake Wheel as an Assembly

 **Unexpected movement or hazardous voltage can cause injury or death. Disconnect, lock out, and tag out the power source that feeds the brake and all related equipment to prevent power from being applied while inspection and repairs are being performed. Before beginning repairs, try the operational controls to confirm the intended power source is disconnected.**

9.5.(a): Quick replacement of the drive motor and brake wheel, as an assembly, can be accomplished with minimum disturbance to the brake.

9.5.(b): Disconnect, lock out, and tag out the disconnect switch that feeds this equipment to prevent power from being applied while service is being performed.

9.5.(c): Remove both shoe assemblies as described under the topic, "Replacing the Brake Shoes." If the shoes will not be replaced as part of this work order, identify the shoes in order that they can be re-fitted without having to be re-bedded.

9.5.(d): Move the entire brake rod assembly aside to permit unobstructed vertical withdrawal of the brake wheel without damage.

9.5.(e): Remove the motor and brake wheel by lifting straight up until the wheel clears the brake.

9.5.(f): If the brake wheel is to be replaced, install the wheel as described elsewhere.

9.5.(g): Install the motor and brake wheel by lowering it into place.

9.5.(h): Re-install the shoe assemblies as described under the topic "Replacing the Brake Shoes."

9.5.(i): Replace the brake rod and lever assembly.

9.5.(j): Replace all pivot, cotter and hitch pins.

9.5.(k): Test the operation of the brake as described under the topic "Operational Test".

9.5.(l): Verify the brake is still properly centered over the wheel. Make any adjustments as required. See Section 5, "Brake Installation".

9.5.(m): Maintenance and inspection periods depend on operating conditions. High duty cycle applications obviously require more frequent inspections than brakes operating on low duty cycle applications. In either case, we recommend a general inspection every 100 operating hours or every month minimum.

9.6: Inspection

9.6.(a): Electrical connections and mechanical fasteners should be checked for tightness. Inspect the brake wheel to ensure that it is neither damaged nor loose. Inspect the brake mounting bolts for tightness, and that brake shoe clearance settings are within specifications.

9.6.(b): Inspect the brake wheel for unusual scoring, signs of over-heating, cracking or wear. Replace any damaged, cracked or excessively worn brake wheels!

9.6.(c): Inspect the condition of the bearings and bushings as well as the electrical and mechanical integrity of the complete braking system. Make any repairs or adjustments that may be required to ensure proper brake system operation.

9.6.(d): Check the brake wheel run-out at all speeds. See Section 8, "Operational Test".

9.6.(e): Correct operation of the motor can be determined by measuring its operating current. Refer to Motor Nameplate for rated value.

9.7: Lubrication

9.7.(a): Periodic lubrication is not required on these brakes. Oil or any other lubricant applied to any part of the brake may trap airborne contaminants.

9.8: Actuator Working Fluid

9.8.(a): The actuator leaves the factory correctly filled with the fluid and seals for the specified operating temperature range.

9.8.(b): The fluid will not deteriorate in service, and if there are no tell-tale signs of leakage, no additional fluid will be required.

9.8.(c): The actuator working fluid should be checked periodically, but must not be over-filled to ensure an adequate air space is retained to allow for fluid expansion. See Fig. 1 for plug location and proper fluid level.

 **During operation, the actuator's internal temperature and pressure will increase. This is normal but presents a risk of burns and scalds if the filler plug is removed while the actuator is hot. Switch off power to the actuator and allow it to cool to ambient temperature before checking, topping off, or draining hydraulic fluid.**

Table 3: Recommended Hydraulic Fluids

Ambient Temperature				Hydraulic Fluid
Lower Limit °F	Upper limit °F	Lower Limit °C	Upper Limit °C	
-13	+122	-25	+50	C-10 (1)
+32	+176	0	+80	C-46 (1)
-31	+104	-35	+40	Aero 41 (2)
-76	+140	-60	+60	M-20 (3)

(1) C-10 & C-46 are Shell Tellus^(R) products.
 (2) Aero 41 is a Shell^(R) product.
 (3) M-20 is a Bayer^(R) Baysilone product.
 All hydraulic fluids are obtainable from Mondel.

9.8.(d): If additional fluid is necessary for any reason, use only the fluid identified on the

nameplate to ensure compatibility with the installed seals and the specified operating temperature range. **DO NOT OVER-FILL.**

9.8.(e): Table 3 specifies hydraulic fluid types for a range of ambient temperatures

9.9: Brake Adjustments

 **Improper brake operation and loss of load control due to incorrect brake adjustment can result in death or injury to personnel. Under no circumstances is it permissible to allow the brake release lever to bottom out against the hydraulic actua-**

9.9.(a): Wear will be more rapid when the linings are new while the high spots are wearing down as the bedding process takes place. Adjustment will be required soon after the brake has been put into service.

9.9.(b): Brake release lever travel increases with lining wear. This decreases the reserve stroke. Carry out periodic maintenance to reset the reserve stroke as described in Section 6 "Actuator Stroke Adjustment".

9.9.(c): Brake torque decreases as the brake lever drops. On critical applications, such as hoists, brake adjustment should be performed frequently enough so that the torque loss does not result in loss of load control. In no event should the lever be allowed to "bottom out". This results in total loss of braking torque and could result in death or injury to personnel.

Following any adjustment, maintenance or repair on the brake, fully test its operation as described under topic "Operational Test".

10.0: Replacement Parts

10.1: Brake Lining Replacement

10.1.(a): As a general guide, Mondel Engineering recommends that brake linings be replaced when the linings wear down to 1/16" minimum thickness. Table 4, taken from Standard ICS 9-

1993, Part 1: Electromagnetic Brakes, shows NEMA's recommended range of minimum lining thickness for bonded and riveted linings on brake wheels from 8" to 19" diameter.

Table 4

Wheel Diameter (Inches)	Maximum RPM	Minimum Wheel Dia. (Inches) (1)	Lining Thickness (Inches) (2)	
			Riveted (3)	Bonded
8	5000	7.94	0.010	0.016
10	4000	9.92	0.010	0.020
13	3300	12.90	0.010	0.026
16	2600	15.87	0.015	0.032
19	2300	18.87	0.015	0.038

(1) Minimum after re machining.
 (2) Minimum permissible prior to replacement
 (3) Above rivet head at maximum wear point

10.2: Detailed procedures for brake shoe replacement and actuator removal and installation are covered earlier in this manual.

10.3: For other parts replacement, or complete disassembly and rebuild, refer to the exploded view attached to this manual.

10.4: Before returning a brake to service after major repairs or overhaul, carry out all adjustments outlined in this manual followed by a complete operational test.

10.5: Ordering Parts

10.5.(a): For part number and identification refer to the Exploded View and Bill of Material forming part of this manual.

10.5.(b): Always quote the MONDEL serial number when ordering parts.

10.5.(c): For optimum brake life and performance use only genuine MONDEL parts.

11.0: Long Term Storage

11.1: If a brake assembly will not be installed immediately, it can be stored indoors in a dry location indefinitely, or outdoors for a reasona-

ble time if adequately protected from moisture and corrosive atmosphere. The brake assembly must always be protected from direct exposure to the elements unless specifically treated at the factory for use in that environment. Covering with plastic sheeting is not acceptable unless provision is made to prevent condensation under the plastic.

11.2: During storage, rust may form on the surface of the brake wheel. This is not usually a problem with ductile iron wheels, nor is it necessary to clean the wheel before placing the wheel in service. The first few brake applications will polish the wheel.

11.3: Steel wheels may form scale when corroded, and the braking surface may have to be re-machined to remove the scale. See Table 4 for machining limits. Dynamic balance may be affected.

11.4: Before painting a brake, protect all pivot points, pull-rod, actuator piston, brake wheel and linings, etc.

11.4.(a): Data plates and labels must not be removed or painted over.