

Instruction Manual Supplement: Type "S" Latching Hand Release - Optional Equipment

! This Supplement forms part of the Basic Instruction Manual. Be familiar with, and observe, all warnings in the Supplement and the Certified Instruction Manual.

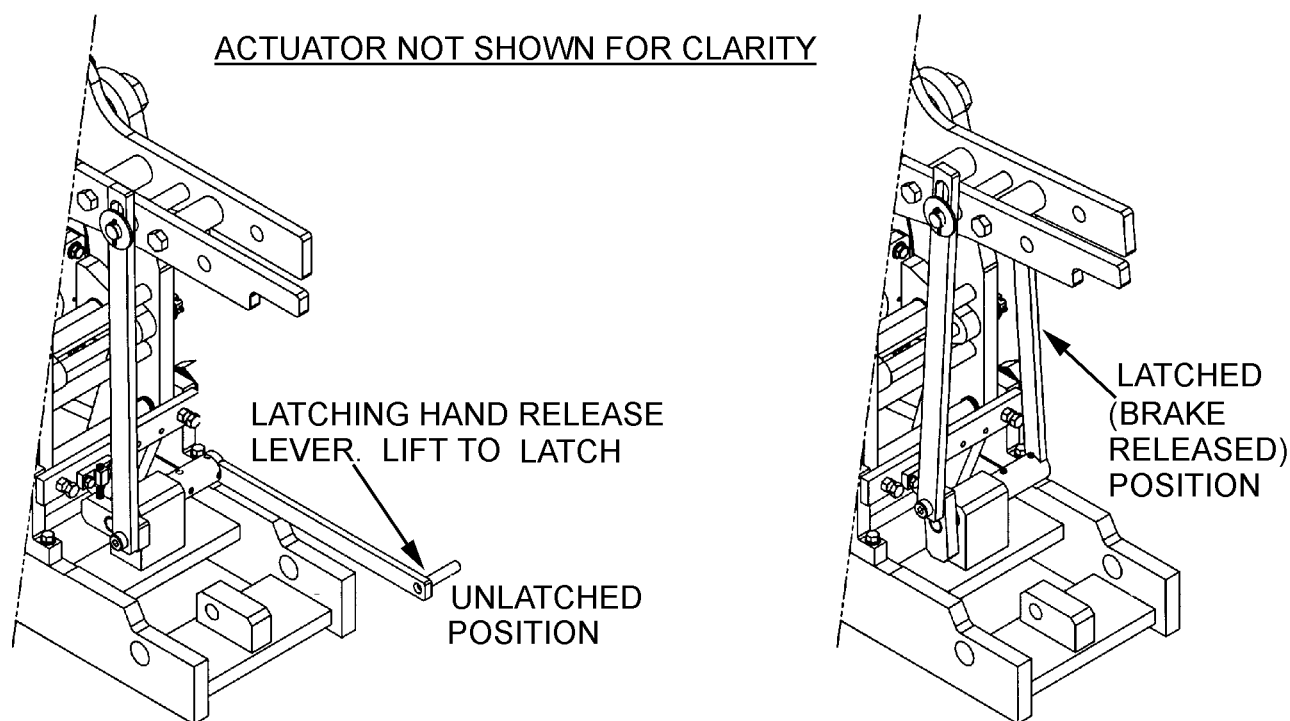

! Before operating the Latching Hand Release, protect against undesirable movement due to the effects of gravity, wind, or other source of energy. Unexpected movement can cause potentially hazardous situations once the brake is released.

1.0: Description

1.0.(a) : The Type "S" Latching Hand Release Lever can be used to gradually release the brake and "Slip the load" under dynamic conditions, or to "latch" in the full open position to allow "hands-free" release for maintenance.

When latched in the fully open position, repairs - such as worn brake shoe replacement, Hy-Thrust actuator or air cylinder service - can be made.

1.0.(b) : To "slip" the load in a hoisting, or similar application, lift the lever as little as necessary to achieve the desired result.

1.0.(c) : To fully release the brake, move the lever from horizontal, a little more than 90°, to beyond vertical. The lever will remain latched in the fully released state until returned to the horizontal.